

# AHUJA®

## PA Mixer Amplifier

250W RMS / 300W Max.

# OPERATION MANUAL

## SSA-250®FX

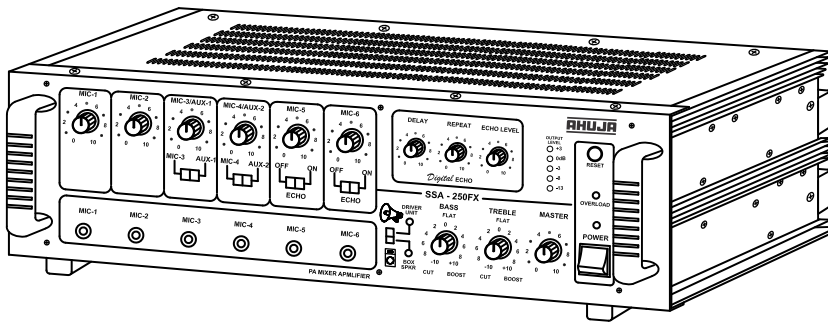

- ◆ Thank you for purchasing the AHUJA PA Mixer Amplifier.
- ◆ Please read this manual thoroughly before making connections and turning on the power. Following the instructions in this manual will enable you to obtain optimum performance from your new AHUJA PA Mixer Amplifier.
- ◆ Please retain this manual for future reference.

## • Safety Instructions

**Read the Instructions:** Please read all the instructions in this section carefully before installation or use of the product. All the safety instructions must be followed.

**Retain the Instructions:** Please retain this Instruction Manual for future reference.



This symbol, wherever it appears, alerts you to the presence of uninsulated hazardous voltage that may be sufficient to constitute a risk of electric shock. External wiring to any terminal marked with this symbol must be done by a trained and instructed person only.



This symbol, wherever it appears adjacent to a component, alerts you that the concerned component can only be replaced by another of the exact same specifications.

### WARNING

- To reduce the risk of electric shock, do not remove the top cover. No user serviceable parts inside. Refer all servicing to qualified personnel only.
- Before replacing any fuse, make sure the set is switched off and disconnected from the AC mains or any other power source. Replace a fuse only with another of exactly same specification.

### CAUTIONS

**Water & Moisture:** To reduce the risk of fire or electrical shock, do not expose this set to rain or moisture. Do not use this set near water or in a wet location. Do not keep any object filled with liquid, such as a vase, on top of this set. Do not insert or remove the AC mains plug with wet hands.

**Power Source:** The voltage & frequency of the AC mains supply, and the voltage of the external battery, (if applicable) to which this set can be connected, is marked on the rear panel of the set. Do not connect this set to any power source other than those specified on the rear panel.

**Power Cord Protection:** Do not cut, kink, damage or modify the AC power cord supplied with this set. Keep the AC power cord away from heaters and harmful chemicals. Do not keep any heavy object on the power cord.

**Operation on Generator:** When operating this set on a generator, make sure the set is switched off till the generator voltage has stabilized.

**Ventilation:** This set should be situated so that its location or position does not interfere with its proper ventilation. Do not cover the ventilation holes / slots. Do not insert or drop anything into the ventilation holes / slots.

**Stability:** This set must be kept in a stable and flat horizontal position, and never in a tilted position. Do not place this set on an unstable stand, tripod, bracket or mount. Do not use attachments which are not supplied or explicitly recommended by the manufacturer.

**Cover Strip:** The cover strip of the 100V / 70V audio output terminal strip, and of any other high voltage output terminal strip, must be replaced after making connections. Failure to do so may result in exposure to hazardous voltages.

**Earthing:** This set must be earthed properly before use. A wire from the Earth terminal on the rear panel must be connected to electrical earth.

**Cleaning:** Disconnect this equipment from the AC mains and external battery before cleaning. Clean with a damp cloth, but do not allow any liquid to enter the set. Do not clean with liquids or aerosols.

**Exposure to Heat:** Do not touch the heatsinks while the set is working.

• **Table of Contents**

<b>Contents</b>	<b>Page No.</b>
• <b>Features/General Description of Product</b> .....	4
• <b>Front Panel Controls &amp; Features</b> .....	5
• <b>Rear Panel Controls &amp; Features</b> .....	6
• <b>Function of Digital Processor</b> .....	7
• <b>Interconnections</b> .....	8
• <b>Speaker Connection Guidelines</b> .....	10
• <b>Typical Applications</b> .....	12
• <b>Specifications</b> .....	16

## • Features/General Description of Product

- Designed for use in a wide variety of PA applications.
- SSA-250®FX is a PA Mixer Amplifier of 250 watts rated output with six unbalanced mic inputs, 2 Aux inputs and a built-in Digital Echo Processor.
- Echo effects with individual Echo ON/OFF switch, is available for 2 Mic inputs ie., Mic 5 and Mic 6. Delay, Repeat and Echo level controls are provided for obtaining desired Echo/Reverb effects.
- SSA-250®FX has a Preamp output for recording on a cassette recorder, a Line output for connecting to a Booster Amplifier and a Line input for connecting to an external PA Audio Mixer.
- A 5 LED array displays the speaker output level. Do not run at such high volume settings that both red LED's are always ON.
- Cut-boost type treble and bass controls provided for tonal adjustment.
- Box Speaker/ Driver Unit selector switch has been provided for protecting the Driver Unit's diaphragm from unwanted low frequencies. Since Box speakers can reproduce the full spectrum of audio frequencies but Driver Units cannot reproduce very low frequencies, the switch should be positioned to the Driver Unit side when Driver Units, Horns and Column speakers are connected.
- Circuit Protector Device has been provided which safeguards the amplifier against overload and short circuit.
- Provision for automatic changeover from AC to Battery Operation if batteries are connected, ensure continuity of program.
- Protection provided against reverse polarity Battery connections.
- Ease of operation, combined with service accessibility has been optimized in the design.

## • Front Panel Controls & Features

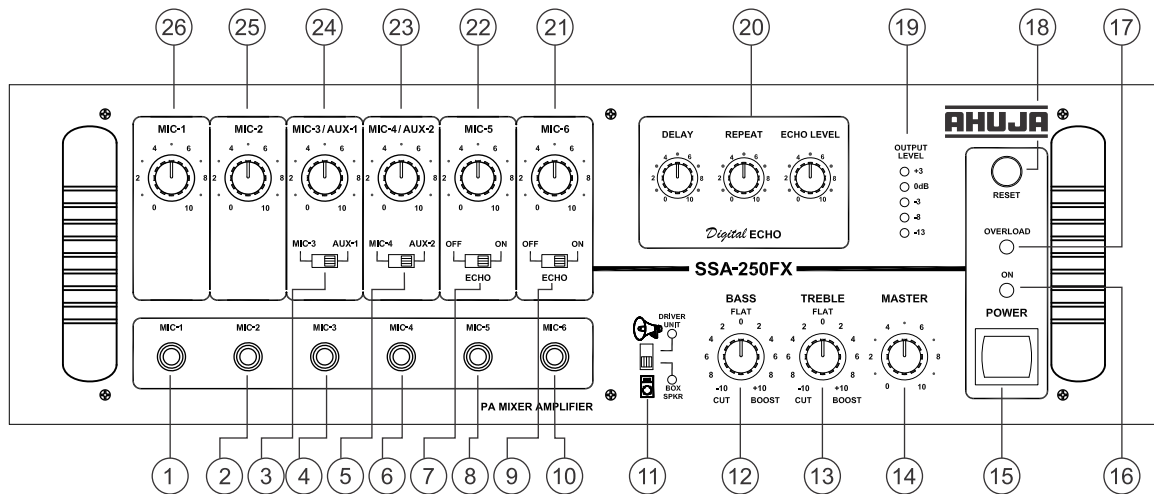

1. **MIC-1 Input Jack Socket**  
For accepting unbalanced signal from a low impedance microphone.
2. **MIC-2 Input Jack Socket**
3. **MIC-3/AUX-1 Selector Switch**
4. **MIC-3 Input Jack Socket**
5. **MIC-4/AUX-2 Selector Switch**
6. **MIC-4 Input Jack Socket**
7. **MIC-5 Echo ON/OFF Switch**
8. **MIC-5 Input Jack Socket**
9. **MIC-6 Echo ON/OFF Switch**
10. **MIC-6 Input Jack Socket**
11. **BOX SPEAKER / DRIVER UNIT Selector Switch**
12. **BASS Control**  
For attenuating or boosting the signal level of low frequencies.
13. **TREBLE Control**  
For attenuating or boosting the signal level of high frequencies.
14. **MASTER Volume Control**  
For adjusting the overall volume level from the amplifier.
15. **POWER Switch**  
Push the top part of the knob to switch the amplifier ON. Push the bottom part of the knob to switch the amplifier OFF.
16. **POWER LED**  
This LED glows when the amplifier is switched ON.
17. **OVERLOAD LED**  
This LED glows when the circuit protector trips.
18. **RESET button**  
This button pops out when the circuit protector trips. Rectify the cause and press the RESET button for resetting normal operation of the amplifier.
19. **LED Array**  
This indicates the output level of the amplifier.
20. **Digital ECHO Facility**  
(Refer Page No. 7)
21. **MIC-6 Volume Control**
22. **MIC-5 Volume Control**
23. **MIC-4/AUX-2 Volume Control**
24. **MIC-3/AUX-1 Volume Control**
25. **MIC-2 Volume Control**
26. **MIC-1 Volume Control**

## • Rear Panel Controls & Features

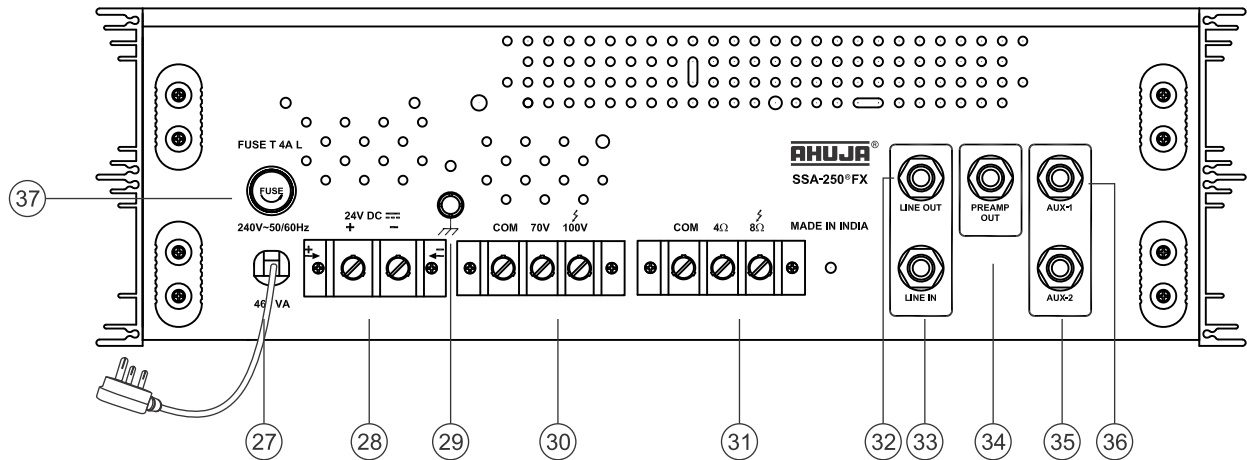

### 27. 3 CORE AC MAINS CABLE WITH PLUG

### 28. BATTERY Terminal Block

For connecting two 12V Car Batteries in series (which becomes 24V) as standby power source.

### 29. EARTH Terminal

### 30. SPEAKER Terminal Block (70V, 100V)

For connecting speakers with 100V line matching transformers.

### 31. SPEAKER Terminal Block (4 and 8 ohm)

For connecting low impedance speakers.

### 32. LINE Output Jack Socket

For connecting to a booster amplifier to obtain combined higher power output.

### 33. LINE Input Jack Socket

For connecting an external Mixer to enhance the number of inputs or for receiving input from the LINE output jack of another amplifier.

### 34. PREAMPLIFIER Output Jack Socket

For connecting to the AUX input of another amplifier or a MP3 recorder for recording purpose.

### 35. AUX-2 Input Jack Socket

For accepting an unbalanced signal from an auxiliary source like a Tuner, MP3 Player, CD player, Echo unit etc.

### 36. AUX-1 Input Jack Socket

### 37. AC MAINS FUSE Rating 4 AMP 250V (T 4A L)

This protects the amplifier from excessive current flow.

### CAUTION

- The equipment must be earthed properly before operating it to avoid electric shock. A wire from the Earth Terminal must be connected to electrical earth for safe operation.

## • Function of the Digital Processor

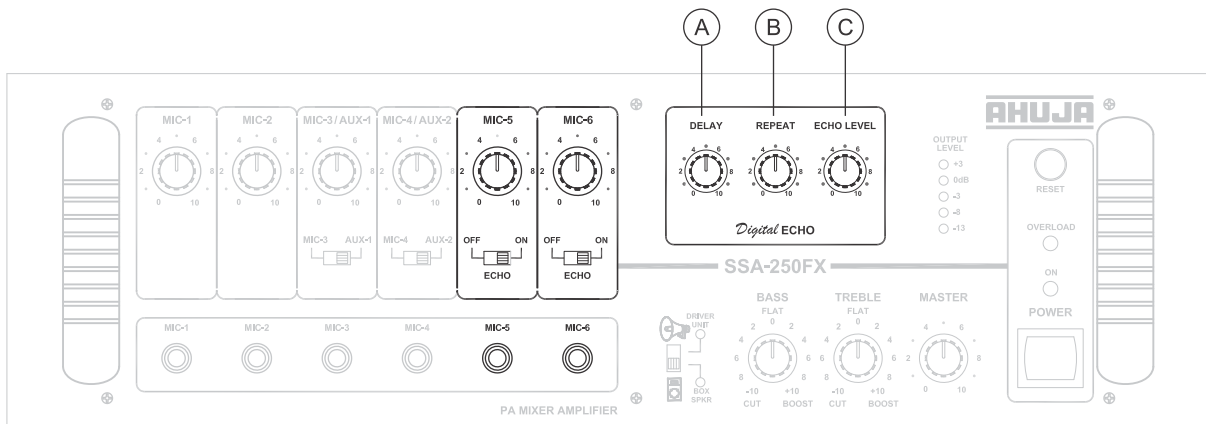

### A. Delay Control

For setting the delay time within the selected range of delay setting.

### B. Repeat Control

Control the number of repetitions of Echo. The higher the setting the more repetitions.

### C. Echo Level Volume Control

For setting Echo Level.

1. Digital effects are available on MIC-5 and MIC-6.
2. MIC-5 and MIC-6 have individual Echo ON/OFF selector switch.
3. Put the selector switch to ON position for Echo effects. When effects are not required then put selector switch to OFF position and keep Delay, Repeat & Echo level volume controls to '0' position.
4. The desired effects can be obtained by adjusting Delay, Repeat and Echo level controls.
5. Adjust the Master Control to set the output level of speakers.

## • Interconnections

- The amplifier can be placed as a tabletop unit. The amplifier should be situated so that its location or position does not interfere with its proper ventilation.
- The amplifier must be powered through an AC earthed mains outlet or 24V DC battery (two car batteries connected in series).
- All connections must only be carried out or changed with the amplifier switched OFF.
- To avoid loud switching noise, always switch ON the Power amplifier after all other units of the audio system have been switched ON. After operation switch it OFF first, then the other units.
- The connection diagrams that follow display the typical types of input sources (Mics, Keyboards, MP3 Players, Mixers, CD Players etc.) and speakers (Wall, Ceiling, Box, Horn, Column) which can be connected to the amplifier. For correct connection and operation check the specification of the connected equipment.



REAR PANEL - SSA-250®FX

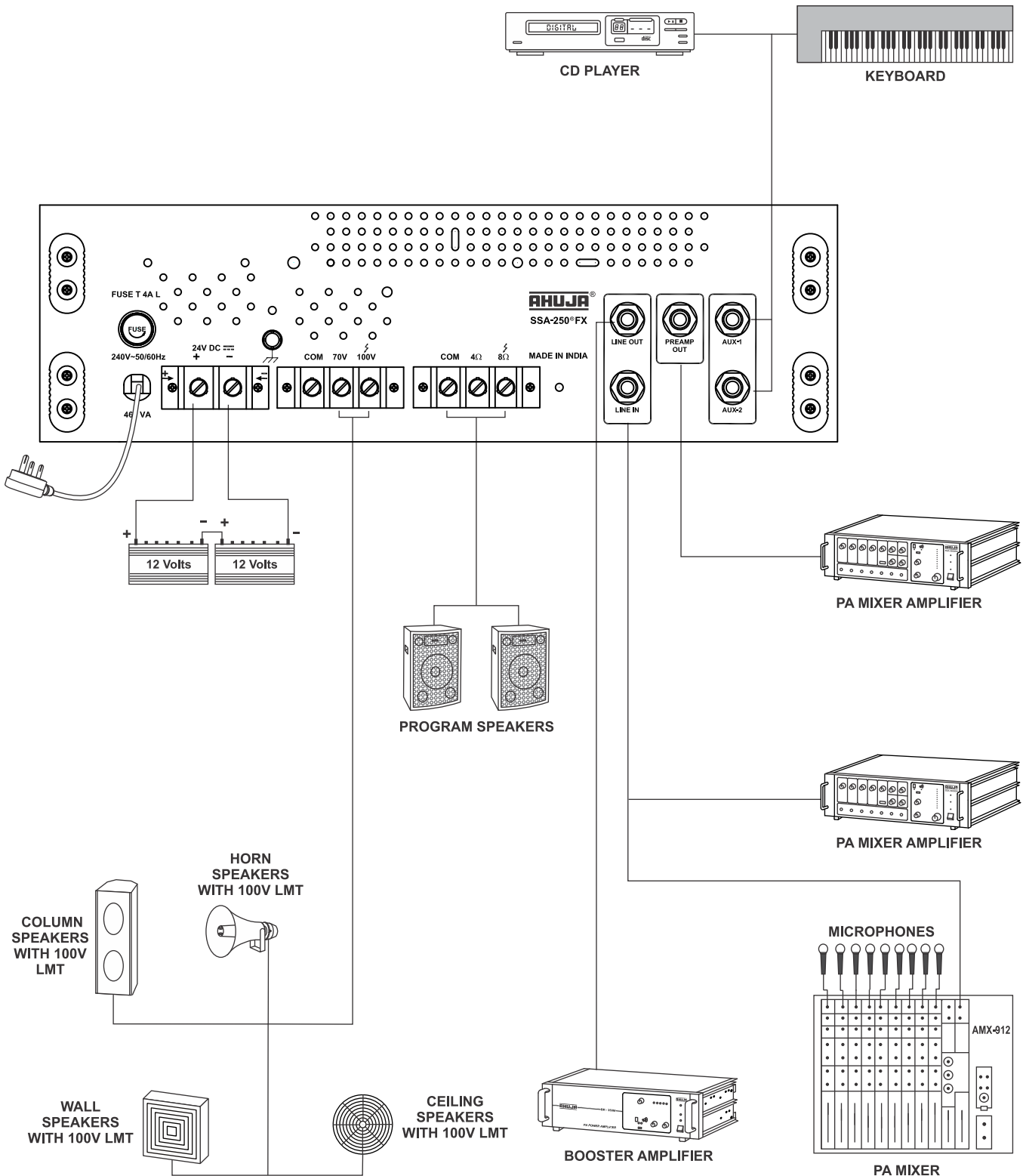

## • Speaker Connection Guidelines

SSA-250®FX is a high powered PA mixer amplifier. It is very important that correct loudspeaker connections are made to avoid damage to the amplifiers or speakers.

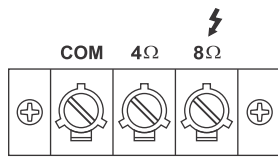

### Low Impedance Speaker Connections

- Box type Speakers can be directly connected to Com-4Ω/8Ω Terminal Strip.
- No Driver Units / Horn Speakers / Column Speakers (with 100V LMT) should be connected to Com-4Ω / 8Ω.

### Connecting SAX-300DX Speaker

- SAX-300DX speaker (300W) should be connected to COM & 8 ohm as shown in figure.

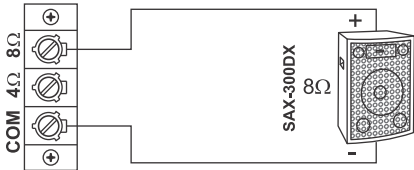

### Connecting Two SRX-220 Speakers

- The Two SRX-220 Speakers (each speaker can handle 200W of power) should be wired in a parallel as shown in figure. The resulting impedance will be 4 ohm. The speaker system should be connected to the 4 ohm tap of the amplifier.

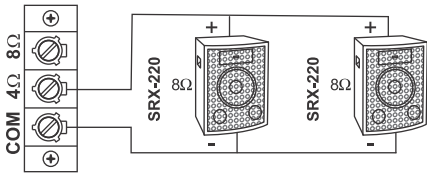

Resultant Impedance =  $(8 \text{ ohm}/2) = 4 \text{ ohm}$

### Correct Phasing of Loudspeakers

When two or more Speakers/Units are installed in the same area and are facing the same direction, it is essential that their cones/diaphragms act in unison. Otherwise the sound level of one speaker will cancel the sound of the other. To avoid any mistake, the terminals of Box speakers and the Driver Units are marked '+' & '-'. Always connect the COM of the Amplifier to '-' of speaker & 4Ω/8Ω of the amplifier to the '+' of the speakers.

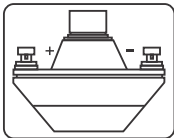

In case of LMT's the COM of all the LMT's should be connected to the COM of the red strip terminal and the power tap to 100V or 70V tap of the amplifier.

### IMPORTANT

- When speakers are connected to COM-4Ω/8Ω Terminal Strip, NO speakers should be connected to the Terminal Strip marked COM-70V/100V.
- Speakers should be connected only to either COM-4Ω or COM-8Ω terminals as illustrated above but never to more than one set of terminals.

### IMPORTANT

- When 70/100 Volt line is being used, no speakers/driver unit should be connected to 4Ω/8Ω (Low Impedance) Tap.
- Loudspeaker/driver unit should be connected to either COM-100V or COM-70V terminals, but never to more than one set of terminals.

# Speaker Connection Guidelines....

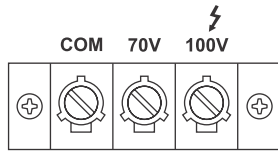

## High Impedance Speakers or Speakers Using A 100V Line Matching Transformer

- Only Driver Units / Horn Speakers / Column Speakers with 100V Line Matching Transformers are to be connected to COM-70V or COM-100V Terminal Strip.
- The Box Speaker / Driver Unit switch must be kept at Driver Unit position.
- When any of the above speakers are connected to the Com-70V / 100V Terminal Strip then NO Box speakers should be connected to the COM-4Ω / 8Ω Terminal Strip.
- The power drawn from the amplifier should not exceed 250 Watts.

## Connecting 25 Driver Units with 100V LMT

- 25 Driver Units with 100V Line Matching Transformer connected at 10 Watts tap can be operated. Alternatively 6 driver units connected at 40W top can be operated. The total load connected should not exceed 250W.

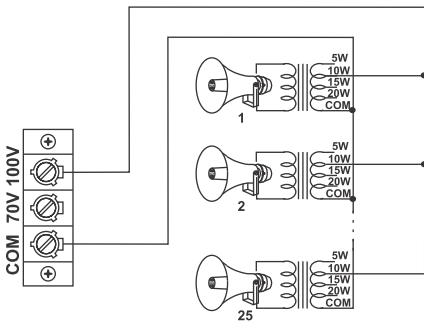

## Connecting a Combination of Driver Units and Column Speakers with 100V LMT

- 20 Driver Units with 100V LMT at 5 Watts and 15 Column Speakers with 100V LMT at 10 Watts can be connected together. The power drawn from the amplifier should not exceed 250 Watts.

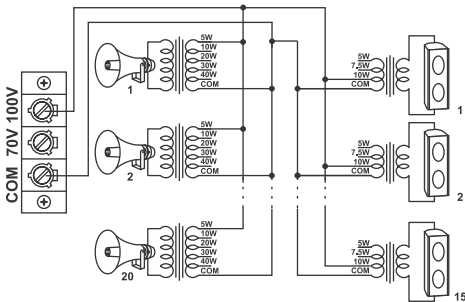

## Connecting a combination of Wall and Ceiling Speakers with 100V LMT

- 40 Ceiling Speakers with 100V LMT at 4 Watts and 15 Wall Speakers with 100V LMT at 6 Watts can be connected together. The power drawn from the amplifier should not exceed 250 Watts.

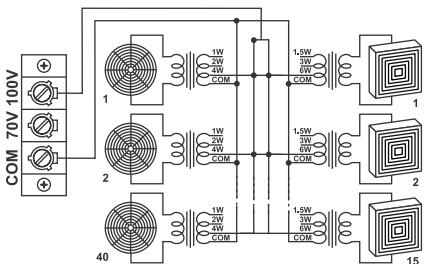

## Use of 70 Volt Line

A loudspeaker / Driver Unit with its LMT adjusted to the 15W tap, when connected to COM and 100V terminals on the Amplifier's Terminal Strip will draw 15W from the Amplifier but when the same is connected to COM and 70V it will only draw half power or 7.5W. A good use of 70V line tap can be made in installations where large number of Speakers / Driver Units are to be installed for more even distribution of sound.

## • Typical Applications

### Connecting SSA-250®FX To two SPA-5000EM To Get A 1250W Mono System

1. Connect Microphones and other Program Sources to the input jacks of the MASTERAMPLIFIER, which is the SSA-250®FX.
2. The Pre-Out jack of SSA-250®FX should be connected to the Input jack of first SPA-5000EM. The sensitivity switch of the SPA-5000EM should be at 200mV.
3. The 200mV output of first SPA-5000EM should be connected to the 200mV input jack of second SPA-5000EM.
4. In this manner the inputs connected to SSA-250®FX will feed all the amplifiers creating a  $(250+500+500) = 1250W$  output system.
5. Loudspeaker connections to both the amplifiers should be done independently. Each of the amplifiers can be connected to either box type speakers or to speakers using the 100V LMT but NEVER to both together. Speaker system impedance should be matched to the output impedance of the amplifier and should be connected to the appropriate tap of the amplifier.
6. When connecting box speakers to an amplifier, the Box Speaker / Driver Unit switch should be set to the Box Speaker side and when connecting driver units, wall, ceiling or column speakers with LMT, the switch should be turned to the Driver Unit side.
7. When speakers with LMT are used, total power drawn should not exceed 500W, each in case of SPA-5000EM & 250W in case of SSA-250®FX respectively.
8. Finally when operating the system, the Bass & Treble controls of the individual amplifiers can be adjusted to give optimum tonal quality of sound to suit the system requirements with the particular speakers connected to that amplifier.
9. This kind of system is ideal where both high and low impedance speakers are being used. Connect low impedance box speaker to one amplifier, and the speakers with LMT to the other amplifier.

*(Refer to page 13 for illustration)*

# • Typical Applications

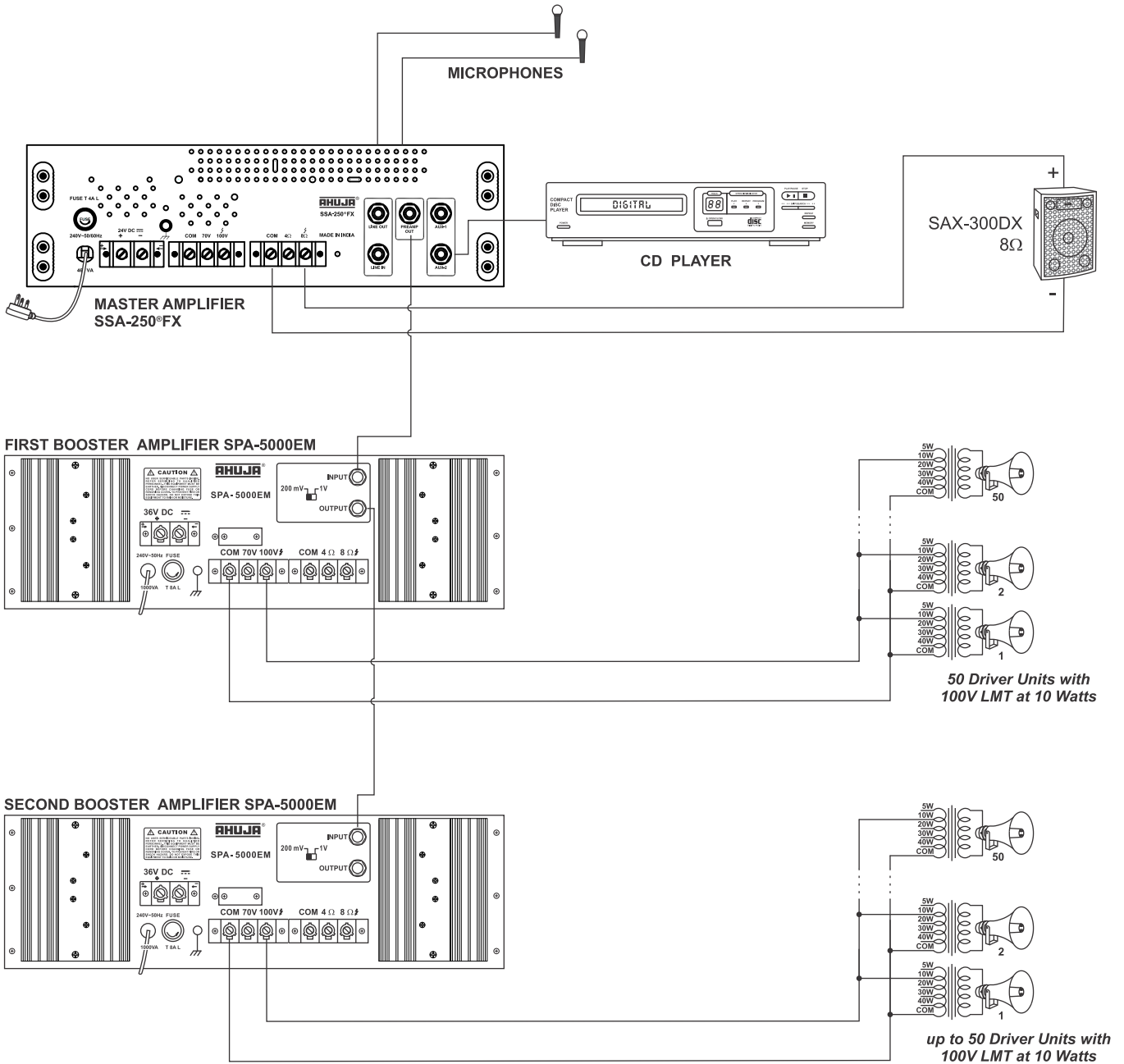

## Typical Applications....

### Connecting One SSA-250®FX with BTZ-10000 For Making A 1250W Mono System

1. Connect Microphones and other Program Sources to the input jack sockets of the Master Amplifier, which is the SSA-250®FX.
2. Connect the Line-Out of the Master Amplifier to the mono input jack socket of the BTZ-10000 using a path cord with 1/4" phone plug at other end.
3. In this manner the inputs connected to the Master Amplifier will feed amplifiers creating a 1250W output system.
4. Loudspeaker connections to each of the two amplifiers should be done independently. Each of the amplifiers can be connected to either Box type speakers or to speakers using the 100V LMT but never to both together. Speaker system impedance should be matched to the output impedance of the amplifier and thus should be connected to the corresponding tap of the amplifier.
5. When connecting box speakers to an amplifier the Box Speaker / Driver Unit switch should be set to the Box Speaker side and when connecting driver units, wall, ceiling or column speakers with 100V LMT, the switch should be turned to the Driver Unit side.
6. When speakers with 100V LMT are used, total power drawn should not exceed 250W in case of SSA-250®FX and 500W on each zone in case of BTZ-10000.
7. Finally when operating the system, any adjustments in the tonal quality of the sound if required can be made from the Master Amplifier.

*(Refer to page 15 for illustration)*

# Typical Applications....

## Connecting One SSA-250®FX and One BTZ-10000 For Making A 1250W Mono System

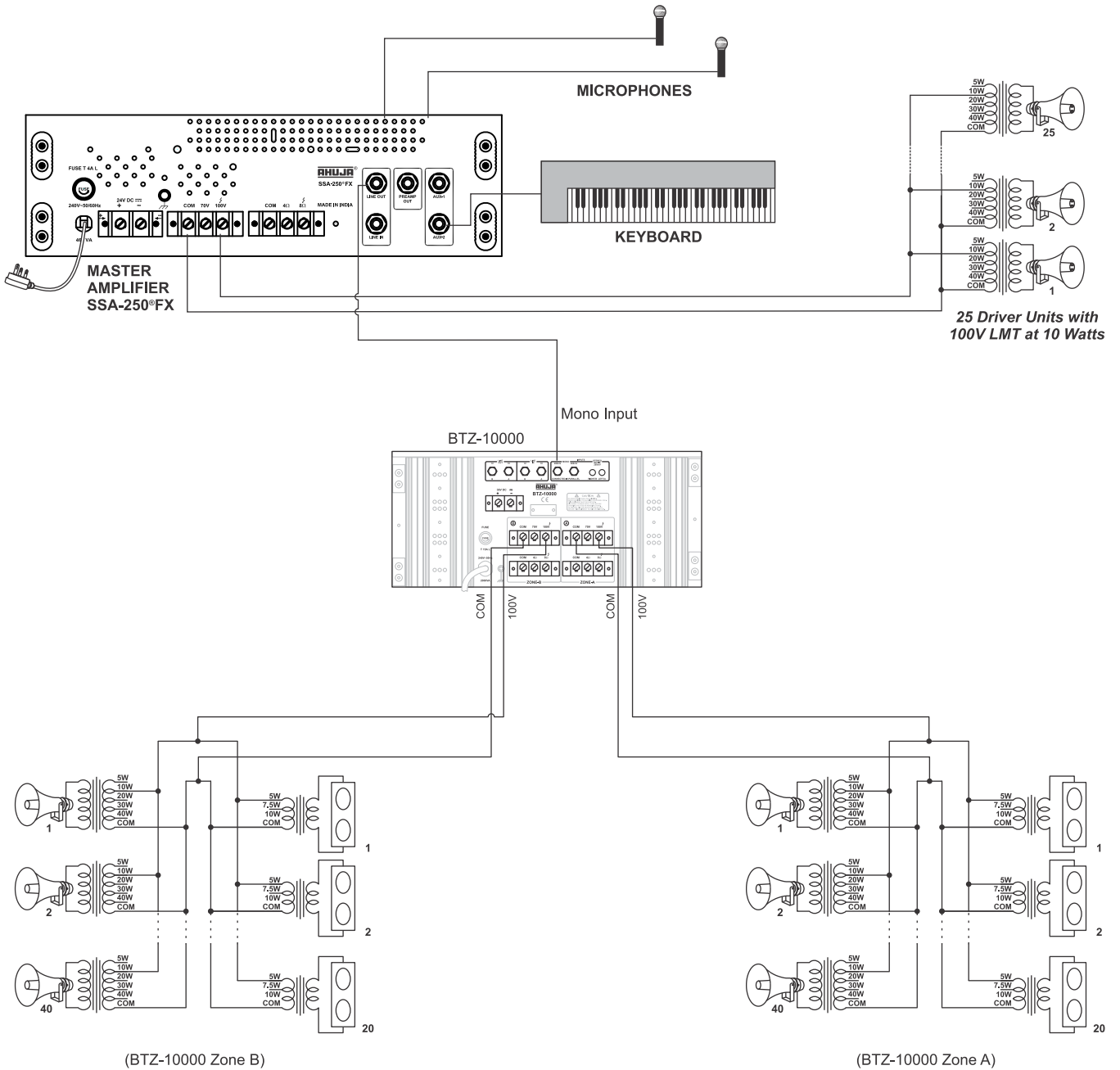

## • Specifications

<b>Model</b>	<b>SSA-250®FX</b>
<b>Power Output</b>	300W RMS Max., 250W RMS at 10%THD 220W RMS at 5% THD, 200W RMS at 2% THD
<b>Output Regulation</b>	≤2 dB no load to full load at 1kHz
<b>Input Channels</b>	6 × Mic. 0.65mV / 4.7kΩ (Mic source impedance 50Ω to 1kΩ) 2 × Aux. 100mV / 470kΩ Line Input 1V / 50kΩ
<b>Delay System Delay Range Setting</b>	Digital Signal Processing 60-300ms
<b>Frequency Response</b>	50 – 15000 Hz ± 3dB
<b>S/N Ratio</b>	60dB
<b>Tone Controls: Switch at Box Speaker Position Switch at Driver Unit Position</b>	Bass: ±10dB at 100Hz, Treble: ±10dB at 10kHz Bass: -10dB at 100Hz, Treble: ±10dB at 10kHz
<b>Pre-amp Output</b>	200mV / 600Ω
<b>Line Output</b>	1V / 1kΩ
<b>Output Taps for</b>	4 & 8Ω (for direct connections)
<b>Speaker Matching</b>	70 & 100V Line (for use with LMT)
<b>Power Supply</b>	AC: 220-240V 50 / 60Hz (110V on request) DC: 24V (2×12V Car Battery)
<b>Protection</b>	AC: Fuse 4Amp. (T 4AL); DC: 14Amp. Circuit Protector
<b>AC Power Consumption</b>	460 VA
<b>DC Power Consumption</b>	6A
<b>Dimensions</b>	W450 × H160 × D340 mm
<b>Net Weight</b>	15.70 kg approx.

- Design and Specifications are subject to change without notice owing to continuous product upgradation.
- Technical specifications are subject to production tolerances.

**AHUJA RADIOS** • 215, Okhla Industrial Estate, New Delhi - 110 020, INDIA  
Tel.: +91-11-26831549, 41612474 Fax : +91-11-26847287  
E-mail: ahuja@ahujaradios.com, admin@ahujaradios.com  
Website: www.ahujaradios.com

- Design and Specifications are subject to change without notice owing to continuous product up-gradation
- Technical specifications are subject to production tolerances.
- We cannot be held responsible for printing errors, should they occur.
- AHUJA is a registered trademark of Ahuja Radios in India and other countries.
- © Copyright Ahuja Radios, 2017. All rights reserved. Any unauthorized reproduction or use of logos, images or design elements is strictly prohibited by law.
- No part of this compilation may be reproduced in any manner or translated without written permission.

